

MODULAR CASHIER COUNTERS



Essence™ Series

Item # _____ Quantity _____

Project _____

MODELS

CSE30 CSO30 CSD30

OPTIONS & ACCESSORIES

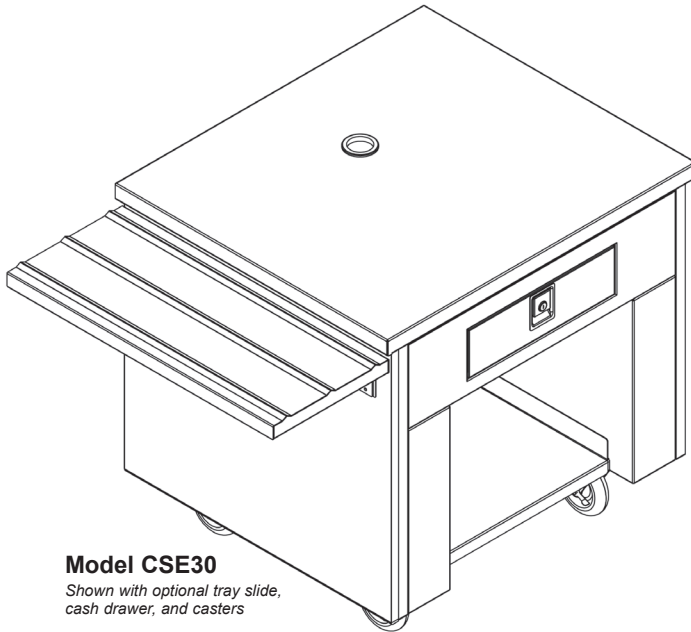

Model CSE30
Shown with optional tray slide,
cash drawer, and casters

- ▶ Durable, welded stainless steel tubular frame
- ▶ Patented TIGHT LINK™ interlocking mechanism eliminates vertical and horizontal gaps between counters
- ▶ Heavy duty 14-gauge stainless steel countertop
- ▶ Millwork panels match or complement any décor
- ▶ 6" high stainless steel adjustable legs
- ▶ Includes 120 VAC duplex receptacle and data box
- ▶ Grommet hole (2¾") in counter top for POS terminal power cords

Counter Type

- Single side Dual sided
- Double-sided island (35" wide)
- Custom sizes/configurations, consult factory

Counter Top

- Stainless steel (std.) Corian® solid surface
- Quartz
- Backsplash/end splash where abutting walls

Tray Slide(s)

- V-ridge stainless steel Flat stainless steel
- Quartz Corian® solid surface
- Counter top extension-flat
- Counter top extension with stainless steel runners

Counter Height

- 34" high (standard) Available between 30" to 36"
Specify _____

Front & End Panels

- Plastic laminate (std.) Stainless steel
- Graphic panel

Electrical Options

- Additional duplex outlet, in cabinet base

Casters & Toe Plate(s)

- Stainless steel adjustable legs (std.)
- Stainless steel seismic legs with flanged feet
- 6" casters with 5" wheels
- 6" adjustable-height casters with 3" wheels
- Stainless steel toe plate(s)
- Black powder coat finish toe plate(s)

Other Options/Accessories

- Cash drawer with lock and compartmented cash tray (mounted in counter apron)
- Stainless steel doors on operator side
- Doors to match front panel with satin chrome tab handle (island and self-service/wall type counters)
- Locks on doors
- Additional grommeted hole(s) Quantity _____
- ADA clearance for cashier/operator *

* Dimensions of counter will change to accommodate clearance requirements.



MULTITERIA • 4900 W. ELECTRIC AVENUE • WEST MILWAUKEE, WI 53219
OFFICE: 414.902.6400 • FAX: 414.902.6446 • INFO@MULTITERIAUSA.COM • WWW.MULTITERIAUSA.COM

MODULAR CASHIER COUNTERS

Essence™ Series

MODELS

- CSE30
- CSD30
- CSO30

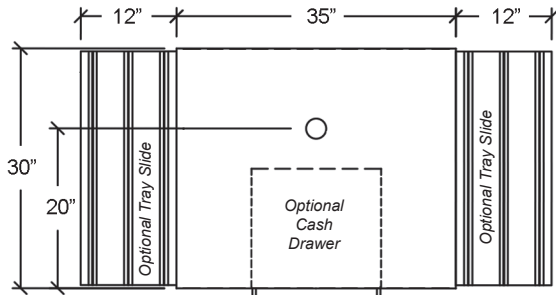

Model CSD30

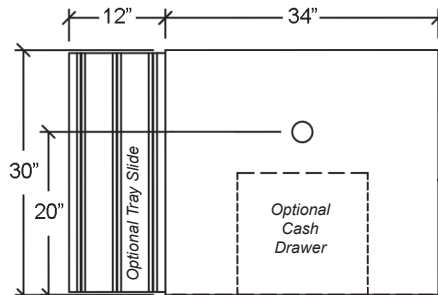

Model CSE30

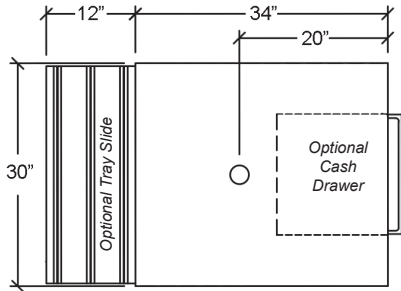

Model CSO30

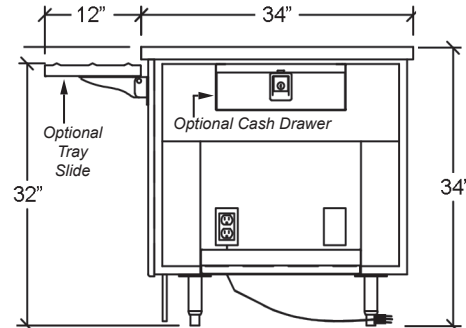

**Model CSE30
Elevation**

SPECIFICATIONS

General:

Shall be Multiteria Model #CS__30 to be constructed with heavy-duty welded stainless steel tubular frame. Countertop to be manufactured with 14-gauge stainless steel with 1½" top turndown all welds to be ground and polished to provide #4 finish. Counter to have easily removable ¾" laminated front and end panels. All millwork panels to have standard plastic laminate on front and white laminate interior.

Body Frame:

Shall be welded and polished, 1" stainless steel tubular framework. Body frame made to readily accept ¾" laminated panels to allow panel changing without the use of tools. Body frame made to accept TIGHT LINK™ (patented) fastening system. Base to be furnished with removable stainless steel undershelf. Undershelf depth to allow 4" clear open space for mechanical connections during installation. Unit shall rest on 6" high stainless steel legs with stainless steel adjustable feet.

TIGHT LINK™ system:

Furnish with patented slide-in panel(s) that link adjacent counters together their entire depth and height to eliminate top, front and rear horizontal and vertical gaps between equipment. Linking panels are open to allow mechanical connections to run through adjoining counters without having to cut access holes, reducing the number of building mechanicals required to connect equipment.

MODEL DETAILS

Model	Description	Ship Wt. (Lbs.)
CSD30	Double-sided (Operator at end of counter)	218
CSE30	Single-sided (Operator at end of counter)	210
CSO30	Single-sided (Operator at back of counter)	210

Front & End Millwork Panels:

Millwork panels to be constructed of ¾" wood substrate with standard plastic laminate on front and white laminate interior, color matching edge banding on top and sides, and black rubber T-molding on bottom edge. Panels are removable for service access. End panels are removable without use of tools.

Countertop:

Counter top is 14-gauge stainless steel with 1½" turned down edges and stainless steel support channels.

TIGHT
LINK
Panel



MULTITERIA • 4900 W. ELECTRIC AVENUE • WEST MILWAUKEE, WI 53219

OFFICE: 414.902.6400 • FAX: 414.902.6446 • INFO@MULTITERIAUSA.COM • WWW.MULTITERIAUSA.COM