

BREAKFAST CART

Item # _____ Quantity _____

Project _____

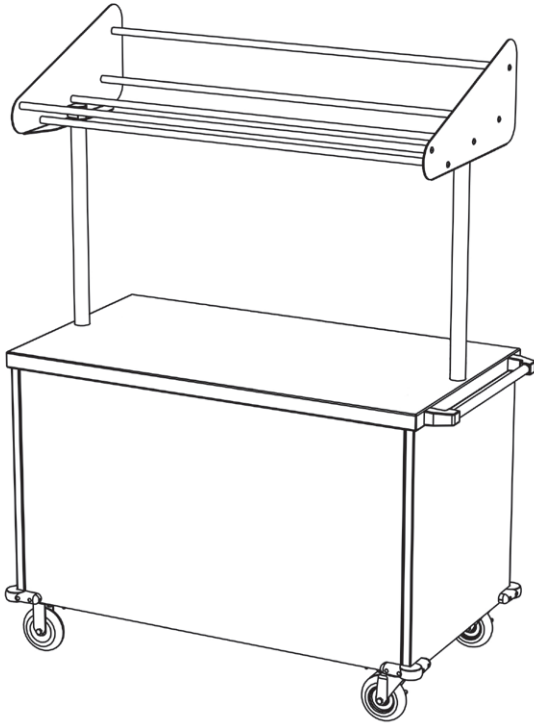

**MODEL
BC660**

- ▶ Durable welded stainless steel construction
- ▶ Top with insulated ice bin or solid serving surface
- ▶ Adjustable-height overshelf rack accommodates baskets or bins
- ▶ Choice of optional laminate exterior finishes
- ▶ Choice of vertical ergonomic or horizontal push handles
- ▶ Spacious interior compartment stores additional food and beverages for convenient resupply
- ▶ Corner or full perimeter bumpers
- ▶ Optional 18" stainless steel drop leaf with grommet hole accommodates payment register
- ▶ Heavy-duty 5" diameter with rounded cushion-tread for quiet, easy movement

*Merchandise Healthy Breakfast And
Snack Items In High Traffic Locations*

OPTIONS & ACCESSORIES

Countertop

- Flat stainless steel (std.)
- Stainless steel ice bin

Handle

- Dual vertical
- Single bar horizontal (std.)

Exterior

- Stainless steel (std.)
- Laminate with graphic

- Laminate
- Magnetic graphic

Exterior Laminate

- Navy Blue
- Spectrum Blue
- Hunter Green
- Burgundy
- Port
- Other _____

Exterior Graphic Panels

- Good Food + Action
- Snack Shack
- Healthy Starts Yogurt
- Grab 'N Go
- Morning Munch
- Custom

Bumpers

- Corner (std.)
- Full perimeter

Other Accessories

- Wicker baskets (3 Ea.)
- Intermediate shelf
- Semi-pneumatic casters (6" diameter)
- Plastic tubs (3 Ea.)
- Hinged compartment doors with lock
- 18" stainless steel drop leaf with grommet hole

Standard Laminates

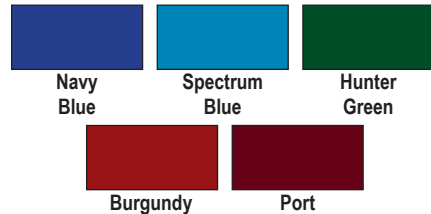

Standard Graphic Panels



Break Fast



Good Food + Action



Morning Munch



Snack Shack



Healthy Starts Yogurt



Grab 'N Go

BREAKFAST CART

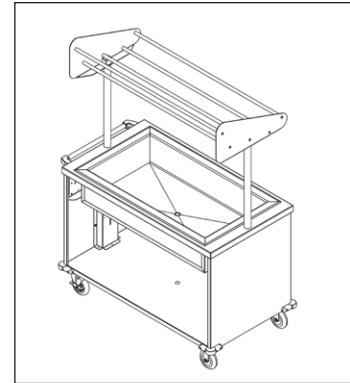
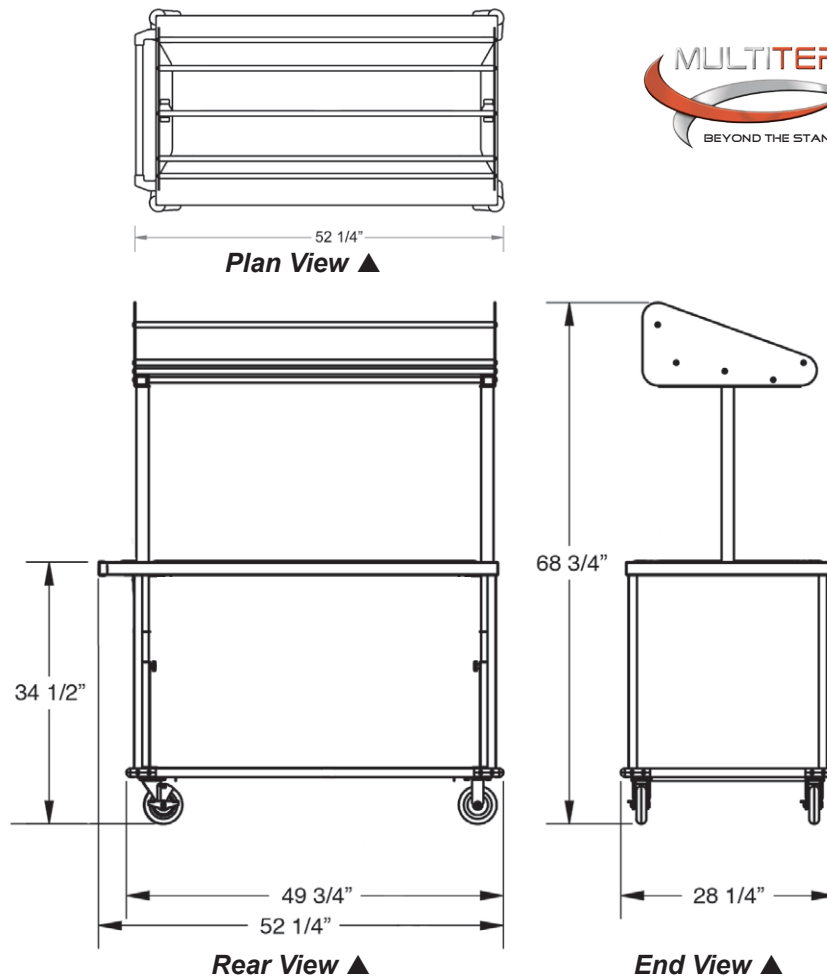

Rear view shown with optional stainless steel ice bin.



Shown with optional drop leaf, wicker baskets, ice bin, vertical handles, laminate exterior, perimeter bumper, and vinyl graphic panel.

Model Detail

Model	Overall Size			Interior Compartment			Top W x H	Ice Bin ²			Casters		Ship Wt. Lbs.
	W	L	H ¹	W	D	H		W	L	D	Type	Dia.	
BC660	28"	52 1/4"	68 3/4"	43"	26"	25 1/2"	26 3/4" x 48"	20"	38"	8"	2 Ea. Swivel/Brake 2 Ea. Fixed	5"	373

¹ With overhead bin rack in highest position. Optional semi-pneumatic casters add 1" to O.A. height. ² Adds 33 lbs. to overall ship weight.

Specifications

Unit shall be of welded stainless steel construction. Cabinet shall have 18-gauge sides, front and floor/base. Top shall be 16-gauge. Overhead bin rack shall be height-adjustable, with a 4" height range, and mounted on 2" diameter stainless steel tubing uprights. Unit shall feature either single horizontal or dual vertical push handle(s), and either corner or full-perimeter bumper(s). Bin rack shall accommodate 15" x 20" tubs or wicker baskets.

Casters

Unit shall have four each extra-load plate type casters, two fixed and two swivel with brake, mounted to a galvanized steel dolly on unit base. Caster wheels shall be 5" diameter with non-marking, rounded cushion tread.

Ice Bin (optional)

Shall be of insulated stainless steel welded construction with center drain and plastic drain tube with shut-off valve. Inside dimensions shall be 20"W x 38"L x 8"D.

Graphic Panel (optional)

Graphic panel image is applied directly to the front unit panel utilizing Commercial Graphic Film manufactured by 3M® Controltac Graphic Film. Five (5) graphic designs to choose from, or optional custom graphics can be designed. End panels shall be stainless steel or standard laminate from Wilsonart or Formica.