

MODULAR LOGK-N-LOAD OPEN TOP COUNTER



Item #: _____ Quantity: _____

Project: _____

Create a custom look with unique interlocking modules!

Essence™ Series

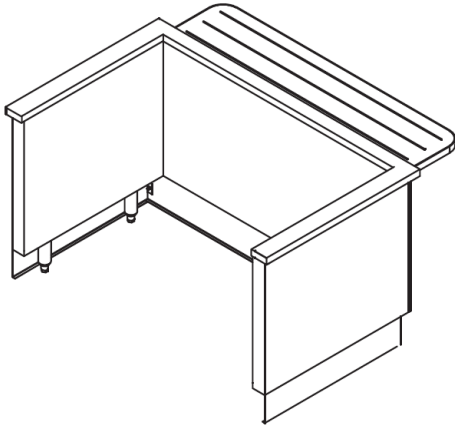

Shown with optional tray slide and toe base.

OPTIONS & ACCESSORIES

Counter Heights

- 34" high (standard)
- Available between 30" to 36"
specify height: _____

Service Type

- Operator service

Countertop Material

- 14-gauge, 300 series stainless steel (standard)
- Zodiac® quartz
- Corian® solid surface
- Green 100% recycled composite
- Laminate
- Common tops available up to 18'-0"
(consult factory)

Exterior Panels

- Laminate panels (standard)
specify mfg./color
- Stainless steel panels
- Custom decorative laminate
(contact factory)

Tray Slide Options

- "V" ridge stainless steel
- Flat stainless steel
- Laminate with plastic tray runners and vinyl edge
- Zodiac® quartz
- Corian® solid surface
- Stainless steel runners
- Continuous top extension (in lieu of tray rails)
- Green 100% recycled composite with stainless steel runners

Kickplate & Casters

- 6" adjustable stainless steel legs (standard)
- 6" adjustable stainless steel legs with flanged feet to bolt to floor
- 6" casters (not available on free standing counters)
- 6" adjustable height NSF casters
- Black powder coated kickplate
- Stainless steel kickplate

Food Protector Style

- FS (Standard)
- VG Captur™
- M
- Other, specify: _____

Display Shelves

- Single tier glass display shelf
- 2-tier glass display shelf

Food Protector Options

- Black powder coat finish (standard)
- Stainless steel
- Other powder coat finish
(verify) R.A.L. color _____
- Heat lamp strip with lights
- Heat lamps-decorative with lights
- Fluorescent lights

Operator Work Ledge

- White poly carving board on fixed brackets
- White poly carving board with fold-down brackets
- Stainless steel 8" work ledge with fold-down brackets

Electrical Options

- Duplex outlet, flush
- Other, specify: _____

Signage Package

- Counter mounted
- Floor model
- Ceiling/wall mounted
- Other: _____

MODELS

- | | | |
|-----------------------------------|-----------------------------------|-----------------------------------|
| <input type="checkbox"/> LNL-OT30 | <input type="checkbox"/> LNL-OT54 | <input type="checkbox"/> LNL-OT78 |
| <input type="checkbox"/> LNL-OT36 | <input type="checkbox"/> LNL-OT60 | <input type="checkbox"/> LNL-OT84 |
| <input type="checkbox"/> LNL-OT42 | <input type="checkbox"/> LNL-OT66 | <input type="checkbox"/> LNL-OT90 |
| <input type="checkbox"/> LNL-OT48 | <input type="checkbox"/> LNL-OT72 | <input type="checkbox"/> LNL-OT96 |

- ▶ **12 standard sizes available**
- ▶ **TIGHT LINK™ (patented)** interlocking mechanism eliminates vertical horizontal gaps between counters.
- ▶ Durable welded 300 series stainless steel tubular frame.
- ▶ Interchangeable exterior panels match or complement any décor.
- ▶ Common tops available up to 18'-0".
- ▶ Interchangeable top configurations available.
- ▶ Stainless steel finished interior back and sides.

MODULAR LOCK-N-LOAD OPEN TOP COUNTER



Item #: _____

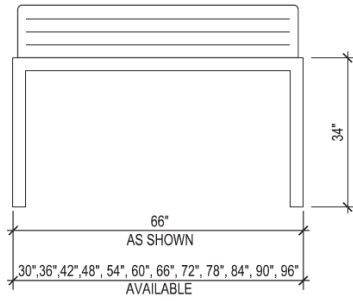

Plan View ▲

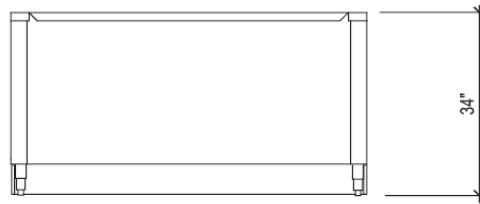

Shown with optional tray slide.
Verify size of buyout unit.

Elevation View ▲

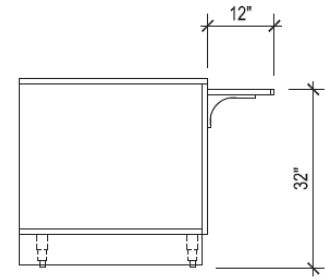

End View ▲

Model	Dimensions L x W x H	Electrical Requirements	Plumbing Requirements
LNL-OT30	30" x 34" x 34"	N/A	N/A
LNL-OT36	36" x 34" x 34"	N/A	N/A
LNL-OT42	42" x 34" x 34"	N/A	N/A
LNL-OT48	48" x 34" x 34"	N/A	N/A
LNL-OT54	54" x 34" x 34"	N/A	N/A
LNL-OT60	60" x 34" x 34"	N/A	N/A
LNL-OT66	66" x 34" x 34"	N/A	N/A
LNL-OT72	72" x 34" x 34"	N/A	N/A
LNL-OT78	78" x 34" x 34"	N/A	N/A
LNL-OT84	84" x 34" x 34"	N/A	N/A
LNL-OT90	90" x 34" x 34"	N/A	N/A
LNL-OT96	96" x 34" x 34"	N/A	N/A

**Mechanical requirements may change depending on options chosen.

Specifications: Short Form

Provide Multiteria Model #LNL-OT_____ to be constructed with heavy-duty welded stainless steel tubular frame. Countertop to be manufactured with 14-gauge, 300 series stainless steel with 1-1/2" top turndown. All welds to be ground and polished to provide #4 finish. Counter to have easily removable 3/4" laminated front and end. All millwork panels to have standard plastic laminate on front and white laminate interior.

Specifications: Detailed

Body Frame: Body to be welded and polished, 1" stainless steel tubular framework. Body frame made to readily accept 3/4" laminated panels to allow panel changing without the use of tools. Body frame made to accept TIGHT LINK™ (patented) fastening system. Base to be open to floor to accommodate under counter buyout equipment. Undershaft depth to allow 4" clear open space for mechanical connections during installation. Unit shall rest on 6" high stainless steel legs with stainless steel adjustable feet.

Front & End Décor panels: All millwork panels to have standard plastic laminate on front and white laminate interior. Panels shall be removable for access for service. Millwork end panels shall be removable without the use of tools.

Countertop: Top shall be 14-gauge, 300 series stainless steel with 1-1/2" top turndown, and shall be removable to allow for service. Top shall include stainless steel support channels and shall be constructed to accommodate remodeling of the counter at a later date to accept an alternate material top without changing the work height.

TIGHT LINK™ (patented)

Furnish with linking system that links adjacent counters together the entire depth and height of the counter. Linking system shall eliminate top, front and rear horizontal and vertical gaps between equipment. Linking system to be open to allow mechanical connections to run through adjoining counters without having to cut access holes, reducing the number of building mechanicals required to connect equipment.



Due to continuing product improvement, units and specifications are subject to change without notice.

MULTITERIA • 1444 N. FARNSWORTH AVENUE, SUITE 203 • AURORA, IL 60505
OFFICE: 630-585-1369 • FAX: 630-585-1397 • WWW.MULTITERIAUSA.COM