

# MODULAR LOCK-N-LOAD SOLID TOP COUNTER



Item #: \_\_\_\_\_ Quantity: \_\_\_\_\_

Project: \_\_\_\_\_

*Create a custom look with  
unique interlocking modules!*

## Essence™ Series

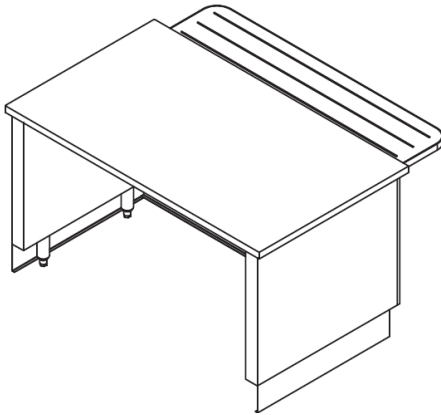

Shown with optional tray slide and toe base.

### OPTIONS & ACCESSORIES

#### MODELS

- |                                |                                |                                |
|--------------------------------|--------------------------------|--------------------------------|
| <input type="checkbox"/> LNL30 | <input type="checkbox"/> LNL54 | <input type="checkbox"/> LNL78 |
| <input type="checkbox"/> LNL36 | <input type="checkbox"/> LNL60 | <input type="checkbox"/> LNL84 |
| <input type="checkbox"/> LNL42 | <input type="checkbox"/> LNL66 | <input type="checkbox"/> LNL90 |
| <input type="checkbox"/> LNL48 | <input type="checkbox"/> LNL72 | <input type="checkbox"/> LNL96 |

- ▶ **12 standard sizes available**
- ▶ **TIGHT LINK™ (patented)** interlocking mechanism eliminates vertical horizontal gaps between counters.
- ▶ Durable, welded, 300 series stainless steel tubular frame.
- ▶ Interchangeable exterior panels match or complement any décor.
- ▶ Common tops available up to 18'-0".
- ▶ Interchangeable top configurations available.
- ▶ Stainless steel finished interior back and sides.

#### Counter Heights

- 34" high (standard)
- Available between 30" to 36" specify height: \_\_\_\_\_

#### Service Type

- Operator service

#### Countertop Material

- 14-gauge, 300 series stainless steel (standard)
- Zodiac® quartz
- Corian® solid surface
- Green 100% recycled composite
- Laminate
- Common tops available up to 18'-0" (consult factory)

#### Exterior Panels

- Laminate panels (standard) specify mfg./color
- Stainless steel panels
- Custom decorative laminate (contact factory)

#### Tray Slide Options

- "V" ridge stainless steel
- Flat stainless steel
- Laminate with plastic tray runners and vinyl edge
- Zodiac® quartz
- Corian® solid surface
- Stainless steel runners
- Continuous top extension (in lieu of tray rails)
- Green 100% recycled composite with stainless steel runners

#### Kickplate & Casters

- 6" adjustable stainless steel legs (standard)
- 6" adjustable stainless steel legs with flanged feet to bolt to floor
- 6" casters (not available on free standing counters)
- 6" adjustable height NSF casters
- Black powder coated kickplate
- Stainless steel kickplate

#### Food Protector Style

- FS (Standard)
- VG Captur™
- M
- Other, specify: \_\_\_\_\_

#### Display Shelves

- Single tier glass display shelf
- 2-tier glass display shelf

#### Food Protector Options

- Black powder coat finish (standard)
- Stainless steel
- Other powder coat finish (verify R.A.L. color \_\_\_\_\_)
- Heat lamp strip with lights
- Heat lamps-decorative with lights
- Fluorescent lights

#### Operator Work Ledge

- White poly carving board on fixed brackets
- White poly carving board with fold-down brackets
- Stainless steel 8" work ledge with fold-down brackets

#### Electrical Options

- Duplex outlet, flush
- Other, specify: \_\_\_\_\_

#### Signage Package

- Counter mounted
- Floor model
- Ceiling/wall mounted
- Other: \_\_\_\_\_

# MODULAR LOCK-N-LOAD SOLID TOP COUNTER



Item #: \_\_\_\_\_

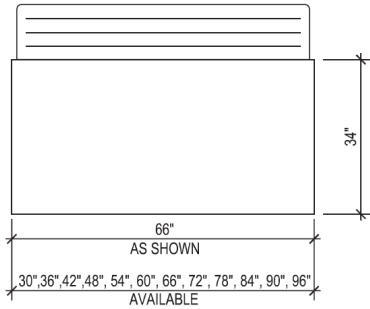

**Plan View ▲**

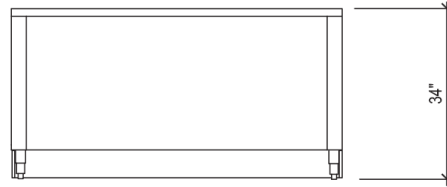

Shown with optional tray slide and toe base.  
Verify size of buyout unit.

**Elevation View ▲**

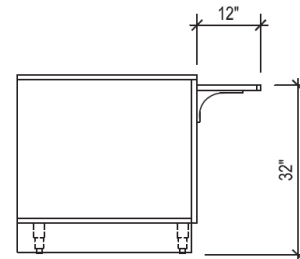

**End View ▲**

Model	Dimensions L x W x H	Electrical Requirements	Plumbing Requirements
LNL30	30" x 34" x 34"	N/A	N/A
LNL36	36" x 34" x 34"	N/A	N/A
LNL42	42" x 34" x 34"	N/A	N/A
LNL48	48" x 34" x 34"	N/A	N/A
LNL54	54" x 34" x 34"	N/A	N/A
LNL60	60" x 34" x 34"	N/A	N/A
LNL66	66" x 34" x 34"	N/A	N/A
LNL72	72" x 34" x 34"	N/A	N/A
LNL78	78" x 34" x 34"	N/A	N/A
LNL84	84" x 34" x 34"	N/A	N/A
LNL90	90" x 34" x 34"	N/A	N/A
LNL96	96" x 34" x 34"	N/A	N/A

Mechanical requirements may change depending on options chosen.

### Specifications: Short Form

Provide Multiteria model #LNL\_\_\_\_\_ to be constructed with heavy-duty welded stainless steel tubular frame. Countertop to be manufactured with 14-gauge, 300 series stainless steel with 1-1/2" top turn-down. All welds to be ground and polished to provide #4 finish. Counter to have easily removable 3/4" laminated front and end. All millwork panels to have standard plastic laminate on front and white laminate interior.

### Specifications: Detailed

**Body Frame:** Body to be welded and polished, 1" stainless steel tubular framework. Body frame made to readily accept 3/4" laminated panels to allow panel changing without the use of tools. Body frame made to accept TIGHT LINK™ (patented) fastening system. Base to be open to floor to accommodate under counter buyout equipment. Undershef depth to allow 4" clear open space for mechanical connections during installation. Unit shall rest on 6" high stainless steel legs with stainless steel adjustable feet.

**Front & End Décor panels:** All millwork panels to have standard plastic laminate on front and white laminate interior. Panels shall be removable for access for service. Millwork end panels shall be removable without the use of tools.

**Countertop:** Top shall be 14-gauge, 300 series stainless steel with 1-1/2" top turn-down, and shall be removable to allow for service. Top shall include stainless steel support channels and shall be constructed to accommodate remodeling of the counter at a later date to accept an alternate material top without changing the work height.

### TIGHT LINK™ (patented)

Furnish with linking system that links adjacent counters together the entire depth and height of the counter. Linking system shall eliminate top, front and rear horizontal and vertical gaps between equipment. Linking system to be open to allow mechanical connections to run through adjoining counters without having to cut access holes, reducing the number of building mechanicals required to connect equipment.



Due to continuing product improvement, units and specifications are subject to change without notice.

MULTITERIA • 1444 N. FARNSWORTH AVENUE, SUITE 203 • AURORA, IL 60505  
OFFICE: 630-585-1369 • FAX: 630-585-1397 • WWW.MULTITERIAUSA.COM