

MODULAR UTILITY OR BEVERAGE COUNTER: WALL UNIT

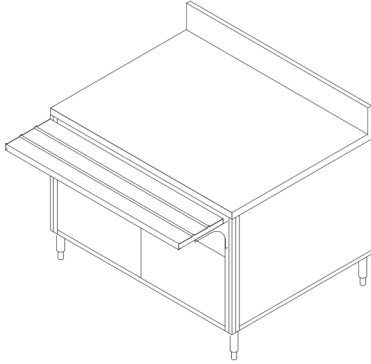

Essence™ Series



Shown with optional tray slide

MODELS

- | | | |
|--|--|--|
| <input type="checkbox"/> ULS30W | <input type="checkbox"/> ULS54W | <input type="checkbox"/> ULS78W |
| <input type="checkbox"/> ULS36W | <input type="checkbox"/> ULS60W | <input type="checkbox"/> ULS84W |
| <input type="checkbox"/> ULS42W | <input type="checkbox"/> ULS66W | <input type="checkbox"/> ULS90W |
| <input type="checkbox"/> ULS48W | <input type="checkbox"/> ULS72W | <input type="checkbox"/> ULS96W |

- ▶ **12 standard sizes available**
- ▶ **TIGHT LINK™ (patented)** interlocking system channel locks two or more units together eliminating gaps between counters.
- ▶ Durable, welded, 300 series stainless steel tubular frame.
- ▶ Interchangeable exterior panels match or complement any décor. Front panel provided with hinged door(s).
- ▶ Common tops available up to 18'-0".
- ▶ Interchangeable top configurations available.
- ▶ 6" rear back splash standard.
- ▶ Open back.

Item #: _____ Quantity: _____

Project: _____

*Designed for "Against the Wall"
Self-Service Application*

OPTIONS & ACCESSORIES

Counter Heights

- 34" high (standard)
- Available from 30"-36" specify height: _____

Countertop Material

- 14-gauge, 300 series stainless steel (standard)
- Zodiac® quartz
- Corian® solid surface
- Green 100% recycled composite
- Laminate
- Common tops available up to 18'-0" (consult factory)

Exterior Panels

- Laminate panels (standard) specify mfg./color
- Stainless steel panels
- Custom decorative laminate (call factory)

Tray Slide Options

- "V" ridge stainless steel
- Flat stainless steel
- Laminate with plastic runners
- Zodiac® quartz
- Corian® solid surface
- Stainless steel runners
- Continuous top extension (in lieu of tray rails)
- Green 100% recycled composite with stainless steel runners

Kickplate & Casters

- 6" adjustable stainless steel legs (standard)
- 6" casters
- 6" adjustable height NSF casters
- Black powder coated kickplate
- Stainless kickplate

Food Protector Style

- FS (Standard)
- VG Captur™
- M
- Other (Specify) _____

Display Shelves

- Single tier glass display shelf
- 2-tier glass display shelf

Food Protector Options

- Black powder coat finish (standard)
- Stainless steel
- Other powder coat finish (verify) R.A.L. color _____
- Heat lamp strip with lights
- Heat lamps-decorative with lights
- Fluorescent lights

Under Counter Options

- Hinged doors (standard)
- Removable under-shelf
- Stainless steel storage compartment
- Pan slides
- Locks (for hinged doors)
- Heated base
- Refrigerated base

Additional Options

- Cash drawer with lock
- Tray dispenser
- Plate dispenser
- Bread storage well
- Stainless steel overshelf
- Self service food shield with stainless steel top shelf
- Two shelf glass display case
- Powder coated posts, uprights and brackets
- Florescent lights
- Infrared heat lamp with lights
- Drip trough with 1" I.W. specify length: _____
- Beverage line cutout(s) specify quantity: _____ specify location: _____ specify size: _____
- Grommet holes for power cords/utility services specify quantity: _____ specify location: _____ specify size: _____
- Other, specify: _____

Electrical Options

- Duplex outlet, flush
- Duplex outlet, pedestal
- Daisy chain for wiring multiple units together
- Electrical load center
- Other, specify: _____

Signage Package

- Counter mounted
- Floor model
- Ceiling/wall mounted
- Other: _____ (consult factory for sign options)

MODULAR UTILITY OR BEVERAGE COUNTER: WALL UNIT



Item #: _____

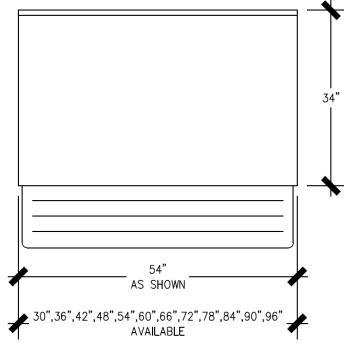

Plan View ▲

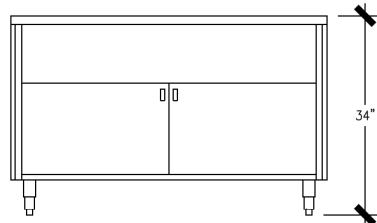

Elevation View ▲

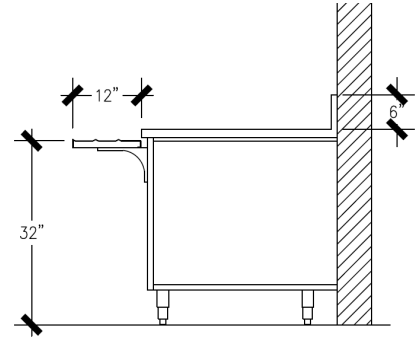

End View ▲

Model	Dimensions L x W x H	Electrical Requirements	Plumbing Requirements
ULS30W	30" x 34" x 34"	N/A	N/A
ULS36W	36" x 34" x 34"	N/A	N/A
ULS42W	42" x 34" x 34"	N/A	N/A
ULS48W	48" x 34" x 34"	N/A	N/A
ULS54W	54" x 34" x 34"	N/A	N/A
ULS60W	60" x 34" x 34"	N/A	N/A
ULS66W	66" x 34" x 34"	N/A	N/A
ULS72W	72" x 34" x 34"	N/A	N/A
ULS78W	78" x 34" x 34"	N/A	N/A
ULS84W	84" x 34" x 34"	N/A	N/A
ULS90W	90" x 34" x 34"	N/A	N/A
ULS96W	96" x 34" x 34"	N/A	N/A

Specifications: Short Form

Provide Multiteria model #ULS____W to be constructed with heavy-duty welded stainless steel tubular frame. Countertop to be manufactured with 14-gauge, 300 series stainless steel with 1-1/2" top turndown. All welds to be ground and polished to provide #4 finish. Unit to have a 6" x 1" back splash. Counter to have easily removable 3/4" laminated front and end panels and hinged door(s) where required. All millwork panels to have standard plastic laminate on front and white laminate interior.

Specifications: Detailed

Body Frame: Body to be welded and polished, 1" stainless steel tubular framework. Body frame made to readily accept 3/4" laminated panels to allow panel changing without the use of tools. Body frame made to accept TIGHT LINK™ (patented) fastening system. Base to be furnished with removable stainless steel undershelf. Undershelf depth to allow 4" clear open space for mechanical connections during installation. Unit shall rest on 6" high stainless steel legs with stainless steel adjustable feet or casters.

Front & End Décor panels: All millwork panels to have standard plastic laminate on front and white laminate interior. Panels shall be removable for access for service. Millwork end panels shall be removable without the use of tools. Laminated hinged doors (where required) to be constructed of same material and mounted to body frame with concealed hinges. Door handle to be satin chrome finish.

Countertop: Top shall be 14-gauge, 300 series stainless steel with 1-1/2" top turndown, and shall be removable to allow for service. Top shall include stainless steel support channels and shall be constructed to accommodate remodeling of the counter at a later date to accept an alternate material top without changing the work height.

TIGHT LINK™ (patented)

Furnish with linking system that links adjacent counters together the entire depth and height of the counter. Linking system shall eliminate top, front and rear horizontal and vertical gaps between equipment. Linking system to be open to allow mechanical connections to run through adjoining counters without having to cut access holes, reducing the number of building mechanicals required to connect equipment.



Due to continuing product improvement, units and specifications are subject to change without notice.